

FreezeAlarm Dialer Pro

User Manual for FA-800E

Thank you for purchasing our FreezeAlarm Dialer Pro. This instruction manual covers installation for model FA-800E.

General Description

The FA-800E automatically calls up to three phone numbers when the temperature either rises above or falls below a customer-determined temperature set-point. It also calls if the power fails for a period of time or if the back-up battery requires replacing. You can remotely check the temperature, power status and battery voltage by calling your FA-800E from any phone in the world. The FA-800E uses a series of menu options that are accessible by pressing the buttons on your Touch-Tone phone. All menus are in English.

The FA-800E can be programmed by either plugging a standard, single line telephone into the front program jack or remotely programming it from an outside telephone or cell phone. The FA-800E indefinitely retains all programmed phone numbers, temperature alarm setpoints and security code information even when the power is out or the back-up battery is either dead or removed.

The FA-800E comes standard with the following sensors:

- Temperature sensor. This sensor comes on a cord that can be extended up to 100 feet (30.5 m) from the base unit. The sensor can detect temperatures from -66°F to 302°F (-55° to 150°C). Additional temperature sensors cannot be added to this FA-800E.
- AC power failure. The FA-800E detects a power failure if the AC power to the base unit fails. Use the programming menu to select the number of minutes (from 0 to 120 minutes) that the power should be out before the FA-800E begins to call the three pre-programmed phone numbers. You can also turn the *Power Alarm Monitoring* feature off so that it never calls with a power out alarm.
- Back-Up Battery. The FA-800E uses a 9 volt battery (not included) for back-up power should the AC power to the unit fail. If the battery's voltage falls below 7 volts, the FA-800E will automatically begin to call your three phone numbers.

FA-800Es are made in China by Emerson Control Products.

For easy future reference during technical support and service, it is recommended that you write your purchase date and the serial number of the unit in the spaces below. The serial number can be found on the bottom instruction label on the FA-800E unit itself. You will also need a four digit security code. This is used to prevent unauthorized remote access to your FA-800E. The factory default security code is 9999. You may keep this or change it to your unique code. Your security code must contain four numeric digits.

Purchase Date: _____

Serial Number: _____

Security Code: _____

Technical Support: Monday-Friday, 8am to 5pm, Central Time
Phone: 800-880-6000
Fax: 952-448-1606
Email: cpi-customerservice@emerson.com
Web: www.controlproductsonline.com

Every effort has been made to ensure the information in this user manual is complete, accurate and up-to-date. Emerson Control Products, Inc. assumes no responsibility for results of errors in this manual nor can it guarantee that changes in equipment made by other manufacturers and referred to in this manual will not affect the operation or intended use of the FA-800E.

Copyright © 2017 by Emerson Control Products Inc.
Document 42420125A

FreezeAlarm, WaterSiren and WaterAlarm are trademarks of Emerson Control Products Inc.
Touch Tone® is a registered trademark of AT&T

This manual may not be reproduced, modified
or distributed without permission from Emerson Control Products Inc.

TABLE OF CONTENTS:

1.0	<i>Initial Set-Up</i>	
1.1	Operating Environment.....	4
1.2	Knowing your way around your FA-800E.....	4
1.3	What you need before you start.....	5
1.4	Use of a DSL, Cable or other Digital Phone Service	6
1.5	Dip Switches and their function	6
1.6	Connecting cords, sensor and battery.....	8
2.0	<i>Programming</i>	
2.1	Quick Program	8
2.2	Explanation of Program Menu Options.....	10
2.3	Programming your FA-800E Locally: At the location where your FA-800E is located	13
2.4	Programming your FA-800E Remotely: By calling into it from a mobile/cell phone or a remote location	14
2.5	Testing your FA-800E.....	15
3.0	<i>Operation of your FA-800E</i>	
3.1	Standby Mode	15
3.2	Calling into your FA-800E to check status and change program settings..	16
3.3	Use of an Answering Machine or Voice Mail at the Monitored Location .	16
3.4	What happens during an alarm.....	17
3.5	How to Cancel the “Alarm Call-Out” and reset your FA-800E	19
3.6	Replacing the Back-Up Battery.....	21
3.7	Disconnecting the FA-800E for seasonal storage	21
4.0	<i>Other Installation Notes</i>	
4.1	Answering machines at the “call to” locations.....	21
4.2	Extending the temperature sensor length	21
4.3	Extending the phone cord length.....	22
4.4	Back-Up Battery Options	22
5.0	<i>Commonly Asked Questions</i>	22
6.0	<i>Trouble Shooting</i>	23
7.0	<i>Warranty and Repair Information</i>	
7.1	Contacting Us.....	26
7.2	Limited Warranty	26
7.3	Repair and Service	27
8.0	<i>Certification Statements</i>	27
9.0	<i>Appendices</i>	
A:	Program Menu, Call-In Menu and Alarm Menu Flow Charts.....	30

1.0 INITIAL SET-UP:

BEFORE YOU PROCEED - Read the Following

Warranty Statement:

Please read the entire warranty statement on page 26 of this manual.

Minimum Installation:

- You should program at least one telephone number to call if there is a temperature, power or battery emergency. The unit will operate without any telephone numbers programmed and you will be able to remotely access the unit to check current status information at the remote location, but without any call-to telephone numbers programmed, you will not receive alarm calls from your FA-800E.
- You must use a back-up battery. A 9V Lithium Battery is highly recommended as a backup battery. This battery is not included with the FA-800E, but is available at most hardware stores. Other back-up battery options are discussed in Appendix A.
- **IT IS CRITICAL THAT YOU TEST YOUR FA-800E to make sure the unit calls out during an alarm condition. Follow the test procedure on page 15.**

1.1 Operating Environment:

The FA-800E should operate in a dry, clean area that is near an AC power outlet and a telephone wall-jack. It is designed to operate in temperatures from 32° to 140°F (0° to 60°C). You should not install in areas where there is strong electrostatic, electromagnetic or radioactive fields. Do not install in an area with high humidity, chemical fumes or corrosive vapors. *Never install or connect during a lightning storm!*

1.2 Knowing your way around your FA-800E:

Descriptions for each function in the diagrams below follow.

Front of the FA-800E

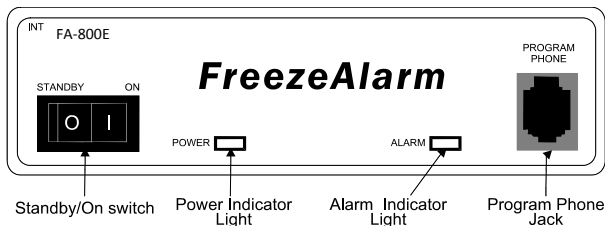

Back of the FA-800E

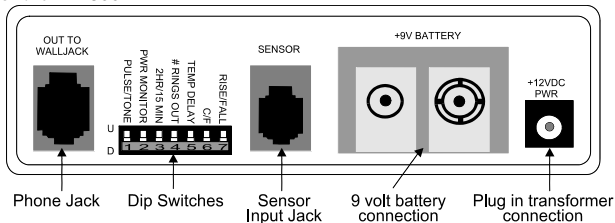

Standby/On Switch	Toggle switch for either STANDBY mode or ON for normal operation mode.
Power Indicator Light	On if the plug-in transformer is plugged in and there is power to the unit. Off if the unit is operating on battery power only.
Alarm Indicator Light	Flashing if the unit is in the STANDBY mode. Off during normal operation with no alarms present. On and not flashing if the unit is in ALARM mode, meaning one of the alarm conditions exists or the alarm call-out has not been canceled.
Program Phone Jack	Plug in a phone here to either locally program your FA-800E or to locally check status or cancel alarm call-outs. <i>For normal operation, you will not leave a phone plugged into this jack.</i>
Phone Jack	Plug in the supplied telephone cord here. The other end plugs into your telephone wall jack (or through a surge suppressor that has the ability to protect the phone line).
Dip Switches	There are seven dip switches that are used to select various features and functions of your FA-800E. Note that the UP position of the switch is towards the top of the FA-800E's case and DOWN is towards the bottom.
Sensor Input Jack	Use this to plug in the temperature sensor. This jack is a slightly smaller than a normal phone jack. This is done to prevent accidental input of the phone line into this jack which could cause harm to the FA-800E.
9 Volt Battery Connection	This is where you will plug in your 9 volt battery.
Plug In Transformer Connection	This is where you will plug in the transformer that is included with your FA-800E.

1.3 What you need before you start:

Before proceeding, make sure you have the following ready:

1. 9 volt battery for back-up power.
2. A high quality surge suppressor that protects the power line as well as the telephone connections. These are available from all hardware stores and department stores.
3. Up to three phone numbers should the FA-800E need to call out during a temperature, power or battery emergency. You may program only one number or program the same telephone number in more than one of the three positions. These phone numbers are referred to as call-to telephone numbers throughout this manual.

4. Access to a single line telephone jack. An existing single telephone line in a home or business will work fine, and the FA-800E will not interfere with the use of your telephone line in any way. It will operate with all standard telephone systems that accept either pulse or tone dialing. Certain private telephone systems and PBX or digital telephone systems may not work. In those cases, a dedicated, single telephone line will be required. Consult the supplier of your phone system if you encounter problems or have questions. The FA-800E cannot be used on a party line or a pay telephone line. **It is extremely important that you test dial out to all your call-to telephone numbers.**
5. You will need a standard telephone to program your FA-800E using the front Programming Phone jack. A cordless phone should work, but if you encounter problems, locate a wired phone or program remotely by dialing into it using a cell phone or a phone from another location. You only need this phone to program the FA-800E locally. After programming is completed, this phone is unplugged from the FA-800E and is not needed for it to operate.
6. If you wish to use one telephone jack for both the FA-800E and a regular telephone, you will also need to purchase a dual telephone jack line splitter. This will turn a single telephone jack on your wall into two separate telephone jacks to plug in both the FA-800E and a regular single line telephone. These are available from any hardware or discount department store.

1.4 Use of a DSL or other Digital Phone Services:

If you have a DSL phone line or a phone line through your cable company, you should install the appropriate filters on the phone line. Please note that the FA-800E is designed to work with and is certified by the FCC to operate on a standard telephone line provided by your local telephone company. A DSL, Cable or Digital phone service may work. If you have questions or problems using one of these types of phone services, contact your phone service provider.

Important: During power failures, many alternative phone services such as DSL and Cable provided phone service **DO NOT WORK**. These phone services require that power be on in the premises for the phones to operate. The FA-800E will **NOT** be able to call out if the power is out when utilizing these phone services. If you have a standard POTS telephone line, power is supplied to this line by the telephone company and is usually not affected if power is out at the monitored location.

1.5 Dip Switches and Their Functions:

There are seven dip switches on the back of the unit. They are set at the factory for the most common installations, but this section describes the feature of each dip switch, should you wish to change any of these functions.

Ignore the ON or OFF labels on the dip switches themselves. Use only the following table for proper explanation of each dip switch setting. UP means the switch should be pointing towards the top of the case and DOWN means the switch should be pointed towards the bottom of the case. All the switches should come from the factory in the DOWN position.

Dip Switch Menu

#	Description	Settings	
1	<i>Pulse or Tone Dial Out.</i> Select for Pulse Dialing only if you do not have Touch-Tone™ dialing capability at the monitored location.	UP = pulse dialing	DOWN = tone dialing
2	<i>Power Alarm Monitoring</i> – you can turn this feature off or on with this switch. If you do not wish to receive an alarm phone call related to a power failure, put switch in the UP position.	UP = Power alarm monitoring is OFF	DOWN = Power alarm monitoring is ON
3	<i>Call Out Frequency.</i> When the unit goes into alarm mode and begins calling out, it will call the three programmed phone numbers. If no one has canceled the alarm call-out, it will begin the sequence again in either 15 minutes or in 2 hours according to the setting selected.	UP = 2 hour call out frequency	DOWN = 15 minute call out frequency
4	<i>10 or 3 Ring Call-Out.</i> If the unit receives no answer when calling a phone number, this switch determines how many times the phone should ring before it hangs up the call and moves on to the next programmed number. This saves on long distance charges. Select the 3-ring option and, if the FA-800E is calling an answering machine set to answer on 4 or more rings, it will hang up before the answering machine answers, saving on any long-distance charge. This may not work in all areas as some telephone companies may still charge for an attempted long distance call which does not go through.	UP = 3 rings	DOWN = 10 rings
5	<i>45 Minute Temperature Alarm Delay.</i> This feature allows the temperature to drop below your pre-selected temperature alarm set point for 45 minutes before going into alarm mode and calling your three phone numbers. This is used frequently to monitor walk-in refrigerators or freezers for a rise in temperature. The 45 minute temperature alarm delay can be enabled so it won't alarm while the refrigerator or freezer is being loaded.	UP = FA-800E will wait 45 minutes before calling.	DOWN = FA-800E will call immediately.
6	<i>Fahrenheit/Celsius Selection.</i> The FA-800E can report temperatures in either degrees Fahrenheit or degrees Celsius. Select °F or °C.	UP = °C	DOWN = °F
7	<i>Rise or Fall.</i> The FA-800E can call out if the temperature gets too low or too high. This switch tells it to go into temperature alarm if the temperature <i>rises above</i> or <i>falls below</i> your desired temperature alarm set point.	UP = Calls out on a temperature rise.	DOWN = Calls out on a temperature fall.

1.6 Connecting Cords, Sensor and Battery:

1. Connect the temperature sensor to the back of the FA-800E marked Sensor
2. Connect the AC adapter (provided) to the back of the unit and the surge protector (recommended) as shown below.
3. Plug in your 9 volt battery to the battery connection on the back of the unit.
4. Using the telephone cord (provided), connect one end to the OUT TO WALLJACK connection on the back and the other end into your telephone jack on the wall. It is recommended you purchase a high quality surge protector that can accommodate a phone line connection. The figure below shows how these connections work, or you may consult the instructions that come with your surge protector.

If you are using a surge suppressor with a telephone line connection, there should be an "IN" and "OUT" connection for the phone lines. Follow the diagram for where the cords should be connected.

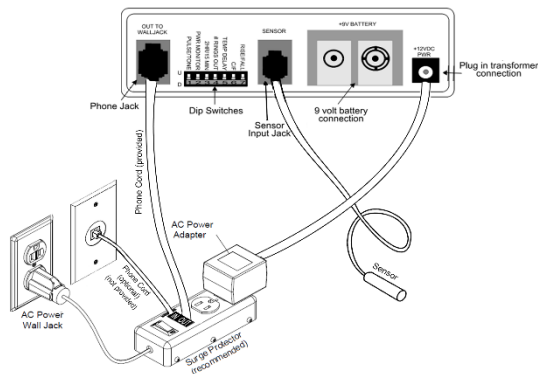

5. Plug in your standard, single line telephone to the "PROGRAM PHONE" jack on the front of your FA-800E. See Figure below.

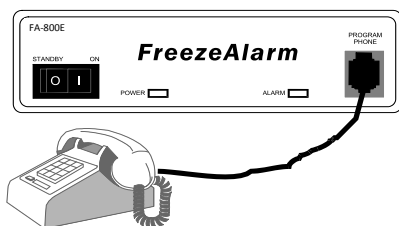

This phone will only be used to program your FA-800E locally or for locally checking current status of your FA-800E. It is important to UNPLUG this phone from the front after you are done programming or making any changes.

2.0 PROGRAMMING:

You can program your FA-800E using a regular home telephone or you can remotely access and program it using a cell phone or a phone at another location. This feature allows you to remotely change programming selections at a later time from any phone in the world. Most first time users program their FA-800E locally, or at the location where the FA-800E is located by using a single line home telephone. A cordless phone may work, but a standard single line home telephone with a wired handset will work best. An explanation of each menu option with helpful hints on programming is provided after the quick programming guide.

2.1 Quick Program:

This provides a quick method to program up to three call-to phone numbers in just a few minutes. You should program at least one call-to telephone number for proper operation. Check the factory defaults if you need to change any other settings as they are not discussed in this *Quick Program* section. When the manual tells you to press a number, it is referring to a number on your program telephone's keypad. If you need an explanation of each menu option, please go to the next section starting on page 10.

1. Make sure the dip switches on the back are set properly for your application.
2. Verify your FA-800E is connected properly and has a 9 volt battery installed.
3. Flip the toggle switch on the front to STANDBY position. The front ALARM light will blink while in STANDBY mode.
4. Plug a program phone into the PROGRAM PHONE jack on the front.
5. Pick up the telephone handset and the Main Menu will begin to play.
6. Press 2 to access the Program Menu.
7. Press 1 to review or program phone numbers.
8. Press 1 to review or program phone number 1.
9. Press 0 to enter a new phone number or to change an existing number.
10. Enter the telephone number followed by the pound “#” key.
11. Press 1 to return to the Phone Number Menu.
12. Press 2 to program phone number 2.
13. Press 0 to enter a new phone number or to change an existing number.
14. Enter the telephone number followed by #.
15. Press 1 to return to the Phone Number Menu.
16. Press 3 to program phone number 3.
17. Press 0 to enter a new phone number or to change an existing number.
18. Enter the telephone number followed by #.
19. Press 1 to return to the Phone Number Menu.
20. Press 1 to return to the Program Menu
21. Hang up or change any of the other settings as needed.
- 22. After programming is completed, UNPLUG YOUR PROGRAM PHONE from the front PROGRAM JACK!**
- 23. FLIP THE TOGGLE SWITCH ON THE FRONT TO “ON” POSITION!**

If this is the first time you have programmed this FA-800E, the factory default settings for the other menu options are as follows:

Security Code 9999
Temperature Alarm Setpoint 45° Fahrenheit or Celsius
Number of rings before the unit answers (incoming ring count)..... 5 rings
Number of minutes the power should be out before calling with a power alarm..... 60
Greeting Message: “Hello, this is your automated monitoring system”
Alarm Message: “Hello, this is your automated monitoring system.
There is an alarm condition at your remote monitored location. The following alarms exist or have existed recently.”



IMPORTANT WARNING! After Programming, you must return the front toggle switch to the ON position or the FA-800E will not call you if an alarm condition occurs and you will be unable to call into your FA-800E remotely!

2.2 Explanation of Program Menu Options:

Each of the various programming options is explained in detail below. Review this before proceeding to program your FA-800E.

Review or Program Telephone Numbers (Menu Option 1):

Program your call-to phone numbers here. You can also review, change or delete any existing phone numbers if needed. The FA-800E can dial up to three phone numbers with each phone number consisting of up to 60 digits. You can include pauses and the star key (*) key as part of your phone number to accommodate calling cards, different phone features and pager systems. These phone numbers are referred to throughout the rest of this manual as “call-to phone numbers”.

To program a star (*) in your phone number, press the * key on your keypad as part of the phone number. To enter a two second pause in a call-to phone number, press the * key twice. This will count as two digits of your total 60 allowed for that number. You can combine * keys in a phone number to add both a two second pause and a dialed * key by having three * keys in your phone number sequence. Three * keys equal a 2 second pause followed by a dialed * key. Four * keys equal a four second pause in the dialing sequence.

IMPORTANT NOTES ABOUT ENTERING YOUR CALL-TO TELEPHONE NUMBERS

- **LONG DISTANCE:** Make sure you enter the phone number exactly like you would dial a voice call. Use a 1 and/or area code if needed. If dialing internationally, make sure you have the correct country codes and follow proper international dialing rules. Check with your phone company for assistance determining the correct number.
- **AREA CODES:** Area codes are often changing and the rules for dialing within an area code also change frequently. Make sure you change your call-to phone numbers if area codes or calling rules change in your area.
- **TEST YOUR FA-800E:** It is *critical* that you test your FA-800E by following the test procedure on page 15. All phone numbers should be tested to ensure they are programmed correctly and that the FA-800E works properly with your phone line.

Deleting Call-To Phone Numbers:

To delete any one of the phone numbers:

1. From the phone number menu, select the phone number you wish to delete (1, 2 or 3). The FA-800E will play the current telephone number.
2. Press 0 (zero) to change the phone number.

3. Instead of entering a phone number here, press the # key to delete the current phone number. The FA-800E will play back a message indicating that phone number slot is now “empty”. This signifies the phone number is now deleted.

Review or Program the Temperature Alarm Setpoint (Menu Option 2):

This menu option lets you set the temperature at which you want the FA-800E to dial out for a temperature alarm. The factory setting for this is 45° whether you have the unit set to read in Fahrenheit or Celsius. You can select a temperature alarm setpoint anywhere from -66 to 301°F (-54 to 149°C). It can read temperatures to you in either °F or °C based on dip switch number six. It will call you if the temperature gets too low or too high based on the position of dip switch number seven.

NOTE FOR A NEGATIVE TEMPERATURE ALARM SETPOINT: To enter a negative temperature alarm setpoint, you will need to precede the desired negative temperature with a * key. For example, if you want a temperature alarm setpoint of negative 15°, press * 1 5 # on your telephone keypad when requested. This will be played back to you by the FA-800E as “negative fifteen degrees”.

Review or Program the Security Code (Menu Option 3):

The security code is used for two functions by the FA-800E.

1. Password Protection to prevent unauthorized persons from accessing your FA-800E remotely. The factory set security code is 9999. It is highly recommended you change this and write the security code down on the front of this manual and in a safe place at all your call-to locations. Security codes must have four numeric digits.
2. Location Identifier. The security code also provides a location code to the person answering an alarm call from the FA-800E. It will note that there is a specific alarm condition “at location #####”. This allows a service or monitoring company to quickly identify which location is calling so they can dispatch service personnel to your monitored location most efficiently. This is also an easy way to hear what your security code is if you have forgotten the code.

If you have forgotten your security code, there is no way to remotely change the code. You will need to go to the monitored location, plug a phone into the front of the FA-800E, go to menu option 3 in the programming menu and review or change the security code at that time. If you are receiving calls from your FA-800E, the unit will tell you the security code during the alarm message.

Review or Program the Number of Rings Before the Unit Answers (Menu Option 4):

This is also referred to as the “incoming ring count”. When you call your FA-800E from a remote location, it will be waiting to hear a specified number of rings before it picks up. You can select the number of rings you wish it to hear before it will pick up. Through this menu option, you can select it to answer after 1 or up to 30 rings have been counted. The factory default incoming ring count is set at five rings.

This feature is provided for several reasons:

1. If you have an answering machine or voice mail at the monitored location, you generally want people calling that location to be able to leave a message. This feature allows you to prevent the FA-800E from interrupting calls that you want to have go to voice mail or the answering machine. To gain access to your FA-800E instead of the message system, follow the procedures outlined in *Use of Answering Machines or Voice Mail at the Monitored Location* on page 16.
2. When you are visiting your monitored location, you may receive frequent phone calls from outside callers. With a smaller incoming ring count selected, there is the possibility it could answer if several callers called in sequence within a three and a half minute period of time. If you normally receive a lot of calls at the monitored location, you may wish to set the incoming ring count to a higher number. This is helpful for businesses who receive a lot of calls or for vacation rental companies that are monitoring multiple locations and don't want their guests to even know there is a FA-800E in their rental property.

Review or Program the Number of Minutes the Power Should be Out Before Calling with a Power Alarm (Menu Option 5):

The FA-800E has the ability to call you if the power to the FA-800E has failed. Through this menu option, you can select the number of minutes that the power should be out before it calls you with a power out alarm. You can select any number of minutes from 0 to 120. The power will have to be out continuously for the number of minutes selected before calling you. For example, if you have the power out timer set at 60 minutes and the power goes out for 40 minutes and then comes back on for a brief moment and then goes off again, the timer resets to zero. It will keep track of the number of minutes the power is out and tell you during an alarm call how long the power has been out and if the power is currently on or off. The factory default for the power out timer is 60 minutes.

To Review or Record Messages (Menu Option 6):

You can record both a greeting and an alarm message on your FA-800E. Each message can be 20 seconds long. The following explains how the messages work.

Greeting Message: This is played whenever you call into your FA-800E from a remote location. This greeting message is helpful if you plan on having relatives or neighbors call into your FA-800E to check on the property. If there is no answering machine or voice mail, you may record a message that indicates this machine does not accept messages and requests the caller to try back later. If you do not record a separate Greeting Message, the factory default message is: *Hello, this is your automated monitoring system.*

Alarm Message: This is played whenever the FA-800E calls out with an alarm. It will precede the factory alarm messages so it can contain personal information about your name, address, etc. It is useful to record an alarm message that will help people at your call-to locations better identify that the call is from your FA-800E. If calling to a monitored service or a contractor, they may also like a custom alarm message that provides address information. The factory default message is: *Hello, this is*

your automated monitoring system. There is an alarm condition at your remote monitored location. The following alarms exist or have existed recently. This is then followed by our factory alarm messages telling you specifically what alarm conditions are or have recently occurred.

If you do record your own custom alarm message, the factory recorded messages indicating the specific alarms that are occurring will still play after your custom alarm message has played.

Reinstating the Factory Default Message:

If you record a custom Greeting or Alarm Message but decide you would rather have the factory default message instead, you can reinstate the factory default alarm or greeting message.

1. Select the menu option 6 to record messages
2. Press 1: *To Review or Program the Alarm (or Greeting) Message*
3. Press 0 so you can change the Alarm or Greeting Message
4. The FA-800E will begin playing the menu prompt shown below. **While this message is playing, press the # key.** The menu prompt will stop and it will now play the factory default greeting or alarm message.

“Begin Recording after the tone.

When you have finished recording, press the pound (#) key”

2.3 Programming Your FA-800E Locally: *At the location where it is located*

1. Make sure the toggle switch on the front of the FA-800E is on the STANDBY position for programming. The ALARM light on the front will begin flashing.
2. Make sure you have a regular, single line telephone plugged into the front of the FA-800E where it says PROGRAM PHONE. This will be referred to as your Programming Phone. NOTE: After programming is completed, unplug the Programming Phone from the PROGRAM PHONE jack on the front. A phone left plugged into the front cannot operate as a regular telephone. If you want to share a phone with your FA-800E in the same wall jack, you will need a telephone jack line splitter. See the *Connecting Cords, Sensor and Battery* section on page 8 for more information.
3. Pick up the handset on your Programming Phone. The FA-800E will begin talking to you with the Main Menu.

Main Menu: *You are now in the main menu. For current status, press 1. To enter the Program Menu, press 2.*

Current Status: Provides the current status of the various sensors.
The current temperature is XX degrees, the power is on (or off), and the battery is at X.XX volts.

Program Menu: The FA-800E is programmed here. Earlier in the manual each menu option is explained in detail. In addition, Appendix A has a full flow chart showing the entire menu layout. You may want to listen to all the menu options before proceeding so you can hear all the options. At the end of the menu, it will pause and then start playing from the beginning again.

4.  **IMPORTANT:** Flip the front ON/STANDBY switch to the ON position for normal operation of your FA-800E.

2.4 Programming Your FA-800E Remotely: *By calling into your FA-800E from a remote phone or cell phone*

1. Make sure all the connections have been made according to section 1.5 on page 8. You will not need to plug a phone into the “PROGRAM PHONE” jack on the front of the FA-800E to program the FA-800E remotely.
2. Flip the toggle switch on the front of the FA-800E to the ON position.
3. From an outside phone or a mobile/cell phone, call the telephone number of your monitored location. The FA-800E will answer after five rings. If you have an answering machine or voice mail at the monitored location, you may need to place two or more calls to the monitored location to bypass the answering machine or voice mail. For more details on this topic, see the section about Answering Machines and Voice Mail on page 16.
4. When the FA-800E answers, you will hear the following:
Hello, this is your automated monitoring system (or a custom greeting message if recorded earlier). The current temperature is XX degrees, the power is on (or off), and the battery is at X.XX volts.

If no alarm conditions are present at the current time, you will then hear:

There are no alarm conditions occurring at this time. To access the main menu, enter your four digit security code followed by the pound (#) key.

If alarm conditions do exist when you call into your FA-800E, it will play any alarm conditions present at that time instead of the above message. See the section *What Happens During An Alarm* for more details on what to do if this message is playing. You can still continue to remotely program the unit even if alarm conditions are present.

5. Enter your four digit security code followed by # on your telephone key pad. If the security code is correct, the main menu will play. If the security code is incorrect, you will be given one more chance and then the FA-800E will say *Incorrect Security Code, good-bye* and then hang up.

Main Menu: *You are now in the main menu. For current status, press 1. To enter the Program Menu, press 2.*

Current Status: Provides the current status of the various sensors.
The current temperature is XX degrees, the power is on (or off), and the battery is at X.XX volts.

Program Menu: This is where you will program your FA-800E. Earlier in the manual, each menu option is explained in detail. In addition, Appendix A has a full flow chart showing the entire menu layout. You may want to listen to all the menu options before proceeding so you can hear all the options. At

the end of the menu, it will pause and then start playing from the beginning again.

6.  **IMPORTANT:** Flip the front ON/STANDBY switch to the ON position for normal operation of your FA-800E.

2.5 Testing Your FA-800E

It is important to test your FA-800E to ensure you have programmed all the telephone numbers correctly and to make sure it is working properly with your telephone line. Before you start the test, make sure the front toggle switch is in the ON position.

To test an alarm call-out based on a cold temperature, wrap the end of the temperature sensor in a plastic bag and insert into a cup of ice. **IT IS VERY IMPORTANT THAT THE TEMPERATURE SENSOR DOES NOT GET WET.** The sensor is not designed for wet environments or for submersion into any liquids. Note that if you have the 45 minute temperature alarm delay “on”, it will take 45 minutes or more before the alarm call-out begins. The temperature alarm delay feature can be changed based on the position of dip switch #5.

You can also test the alarm call-out simply by unplugging the power cord. After your programmed number of minutes that the power must be out, the FA-800E will begin calling your programmed call-to phone numbers.

After you have verified the programmed call-to phone numbers have been called successfully, you must still cancel the alarm call-out. Make sure the temperature sensor is out of the ice and at room temperature again. To cancel the alarm and reset the FA-800E, flip the front toggle switch to the STANDBY position and then again back to the ON position. The red alarm light on the front should go out. Your FA-800E is now ready for operation.

3.0 OPERATION OF YOUR FA-800E:

3.1 Standby Mode:

On the front of your FA-800E is a toggle switch with STANDBY or ON positions. The STANDBY position is primarily used for programming purposes only. The ON position is where it should be once programming is completed. In STANDBY mode, you can access the menus, but you **cannot remotely dial into your FA-800E and more importantly, it cannot call you if an alarm condition occurs.**

Some users may want to temporarily flip the switch to the STANDBY mode if they are visiting the monitored location and don't want the possibility of an incoming call being picked up by the FA-800E. We don't recommend the STANDBY mode for this scenario and instead suggest you change your incoming ring count selection to a higher number so virtually all incoming callers will either go to your answering machine/voice mail or you have sufficient rings to allow you to get to the call well before the FA-800E answers.



NOTE: *If you leave your FA-800E in the STANDBY mode, it will not call you if there is an alarm and you will be unable to call into it from a remote location.*

3.2 Calling into your FA-800E to check status and change program settings:

One of the best features of the FA-800E is the ability to remotely check the current temperature, power and battery status at your monitored location. You can even remotely change any of the program menu settings, including the call-to phone numbers if desired. If you have an answering machine or voice mail at the monitored location, make sure you read the section *Use of an Answering Machine or Voice Mail at the Monitored Location* in section 3.3 before proceeding. The following is the procedure for remotely accessing your FA-800E to check current conditions or change program menu options.

To Check Current Conditions at your Monitored Location:

1. Call the telephone number of your monitored location where it is located
2. When the FA-800E answers, you will hear the following:
*Hello, this is your Automated Monitoring System (Or you will hear your custom greeting message that was recorded earlier)
The current temperature is # # degrees, the power is on (or off), and the battery is at #.# # volts. There are no alarm conditions occurring at this time.
To access the main menu, enter your four digit security code followed by the pound “#” key.*
3. You can either hang up or go into the main menu by entering your four digit security code.

To Remotely Change any Program Menu Settings Including Call-To Phone Numbers:

1. Call the telephone number of your monitored location where it is located
2. When the FA-800E answers, you will hear the factory greeting message or your custom greeting message recorded earlier. This will be followed by the current temperature, power status and battery voltage at your monitored location.
3. Enter your four digit security code followed by # to access the main menu.
4. Press 2 to access the Program Menu.
5. Press the number of the menu option you wish to change and follow the prompts.

3.3 Use of an Answering Machine or Voice Mail at the Monitored Location:

If you have an answering machine or voice mail at the monitored location where your FA-800E is located, there is an easy way to still use your answering machine or voice mail and access the FA-800E to check current status or to cancel the alarm call-out.

The FA-800E will answer after it hears a specified number of rings. This number of rings is the “incoming ring count” selection programmed during the programming section. It can count incoming rings over multiple calls. The multiple calls must be made within three and a half minutes of the first call. This allows most incoming

calls to go to the user's answering machine or voice mail service prior to the FA-800E answering. It will answer based on your "incoming ring count". The factory default incoming ring count is five rings.

How This Works (an example):

1. During Programming, set your FA-800E to answer on a specified number of incoming rings. Then set up your answering machine or voice mail to answer on a number of rings less than the number of rings which signals your FA-800E to answer. For example, if your FA-800E is set to answer on 5 rings, set your answering system to answer on four rings or less.
2. When your monitored location receives an incoming call, it will go to the answering system first because that is set to answer on four or fewer rings while your FA-800E is set to answer on five rings.
3. If you wish to call your FA-800E, place two calls to your monitored location.
 - a. On the first call, let the phone ring two or three times and then hang up before your answering system answers. The FA-800E will remember those first two or three rings in memory for the next three and a half minutes.
 - b. On your second call, let the phone ring another two or three times. Your FA-800E will answer first because it remembered the first two or three rings and with the second set of rings, it accumulated a total of five rings and now answers before your answering machine or voice mail. If you have your FA-800E set to answer on high number of rings, you may need to place more calls to get the FA-800E to eventually answer.

Note that after three and a half minutes, the FA-800E's incoming ring counter will reset to zero. If you receive many incoming calls to your monitored location (like at a business), you would want to set your incoming ring counter to a high number.

NOTE: If you have a high incoming ring count selected, you need to place a number of calls in a short period of time (three and a half minutes) to access your FA-800E remotely.

3.4 What Happens During An Alarm:

The FA-800E will call you if an alarm condition has occurred. It will continue to call you every 15 minutes (or every 2 hours depending upon dip switch #3's position) even if the alarm condition has been corrected, but the alarm call-out has not yet been canceled. Note that canceling the alarm call-out does not disable the FA-800E. The FA-800E will continue to monitor all conditions including those in alarm.

Alarm Call-Out Sequence:

The FA-800E will continue to call all programmed call-to phone numbers until someone acknowledges the alarm and cancels the alarm call-out.

It will call the first call-to telephone number and play its alarm message to a person, answering machine or voice mail. If it gets a busy signal, no answer or a person who doesn't know how to cancel the alarm call-out, it will immediately start calling the second number. If the alarm call-out isn't canceled by the second call-to person, it

will immediately move to the third number. If no one at that call-to number cancels the alarm call-out, the unit will wait either 15 minutes or 2 hours and then start the sequence all over again.

The only way to stop it from calling the call-to phone numbers is to have a person at one of the call-to numbers cancel the alarm call-out as described later in this manual, go to the monitored location and switch the toggle switch to STANDBY and then back again to ON.

The FA-800E is persistent and always wants you to know that an alarm has occurred, even if the alarm condition has corrected itself. For example: The power goes out long enough so that the FA-800E notes a power alarm and begins calling your call-to phone numbers. If none of the people at the call-to numbers are home to answer the call, and the power is eventually restored, it will continue to call the call-to phone numbers until the alarm call-out has been canceled.

Multiple Alarms:

It is possible to receive multiple alarm calls from your FA-800E even if you believe you have canceled one of the alarms. Here are some examples:

Example 1:

If you receive a power out alarm and cancel that alarm call-out, your FA-800E will still be running on back-up battery power until the power is restored. It is conceivable therefore, that the battery could drop below 7.0 volts and begin calling out again, but this time with a battery alarm. You would need to cancel this alarm call separately from the earlier power out alarm. If power continues to be out, you could also receive a separate temperature alarm later because your heating system will most likely not be working. This alarm call-out would have to be canceled separately as well.

Example 2:

Assume you have received a power out alarm and have canceled the alarm call-out. A short time later, you receive another power out alarm. What has happened is that your power was restored after you canceled the first alarm call-out and the power out alarm was automatically reset. A short time later, the power went out again (not infrequent in remote areas). This caused the FA-800E to initiate another power out alarm and begin calling your call-to phone numbers again.

Example 3:

This same multiple alarm call-out can happen with a temperature alarm as well, especially if the temperature outside your monitored location is close to the temperature alarm setpoint you have programmed on your FA-800E. If your heating system fails or power is out, the temperature in your monitored location begins to drop. In the evening, when it is colder outside, it may drop below your temperature alarm setpoint inside the home and then call you with a temperature alarm. Then, during the day, the temperature may return above the temperature alarm setpoint because the sun is out. This would cause the FA-800E to potentially reset during the day and call you again at night – at 2am of course.

3.5 How to Cancel the “Alarm Call-Out” and reset your FA-800E

Two things need to happen to reset the FA-800E. The alarm call-out must be canceled and the alarm condition needs to be corrected. Once both of these things have happened, it will automatically reset.

You can cancel the alarm call-out in one of three methods.

1. If you answer a call from the FA-800E, it will give you an opportunity to enter the four digit security code which will cancel the alarm call-out.
2. If the FA-800E has left alarm messages on your answering machine or voice mail, you can remotely call into it and cancel the alarm call-out by following the prompts.
3. Go to the monitored location and if the it is still dialing out to the call-to phone numbers, you can simply switch the front toggle switch to STANDBY mode and then back again to the ON position. This is a physical reset that can only be done at the monitored location. You will see the red **ALARM** light go off when you reset it in this fashion. Doing this does not erase any programmed phone numbers, security codes or other settings. Those settings will be retained indefinitely even if the power cord is unplugged and the battery is removed.

Canceling the Alarm Call-Out during a call from the FA-800E:

When the FA-800E calls you, you will initially hear either the factory recorded alarm message or your custom alarm message that you recorded during the programming section.

Hello, this is your Automated Monitoring System. (Or you will hear your custom alarm message that was recorded earlier)

There is an alarm condition at your remote monitored location. The following alarms currently exist or have occurred recently.

This will be followed by one or more alarm conditions. A four digit location code will also be played. This is the same number as your security code.

There is a temperature alarm at location ####. The power at location #### has been out for ### minutes and is currently on (or off). There is a battery alarm at location ####. Please check conditions at your monitored location immediately.

This entire message will repeat again and be followed by:

To cancel the alarm call-out, enter your four digit security code followed by the pound “#” key.

You will be given two chances to enter the correct security code. If incorrect two times, the FA-800E will say, *Incorrect Security Code, good-bye* and then it will hang up. If you enter the correct security code, it will respond with:

The alarm call-out is now canceled. To return to the main menu, press 1. Otherwise, hang up.

Calling into your FA-800E to Cancel the Alarm Call-Out:

If you received calls from your FA-800E and know there is an alarm at your monitored location, you can call into it from any phone in the world and remotely cancel the alarm call-out without having to wait for another call. If you have an answering machine or voice mail, read the section *Use of an Answering Machine or Voice Mail at the Monitored Location* on page 17 before proceeding.

Follow this procedure:

1. Call your monitored location's phone number where the FA-800E is located.
2. When the FA-800E answers, you will hear the following:

Hello, this is your Automated Monitoring System. (Or you will hear your custom alarm message that was recorded earlier)

The current temperature is # # degrees, the power is on (or off), and the battery is at #.# # volts.

This will be followed by one or more alarm conditions. A four digit location code will also be played. This is the same number as your security code.

There is a temperature alarm at location # # # #. The power at location # # # # has been out for # # # minutes and is currently on (or off). There is a battery alarm at location # # # #. Please check conditions at your monitored location immediately.

This entire message will repeat again and be followed by:

To cancel the alarm call-out, enter your four digit security code followed by the pound “#” key.

You will be given two chances to enter the correct security code. If incorrect two times, the FA-800E will say, *Incorrect Security Code, good-bye* and then it will hang up. If you enter the correct security code, the FA-800E will respond with:

The alarm call-out is now canceled. You are now in the main menu. From here, you can either access main menu functions or hang up.

If the Alarm Call-Out Has Been Canceled By Someone Else:

Since the FA-800E can call multiple phone numbers, there is a chance that a person at one of the other call-to locations may have canceled the alarm call-out prior to your phone call to it. If that occurs, you will still hear the current status and all the alarm conditions when you call into it, but you will not be given a chance to cancel the alarm call-out. Instead, it will ask for your four digit security code to access the main menu. You can either enter your security code to check current conditions again or hang up and determine the steps needed to correct the alarm conditions.

It is even possible that one of your other call-to people has canceled the alarm call-out and the alarm conditions have improved at your monitored location. If that has

occurred, you will not hear any alarm conditions, but instead, you will be given a current status and then an opportunity to enter the main menu.

3.6 Replacing the Back-Up Battery:

When the battery requires replacing, we highly recommend replacing it with a new 9 volt lithium battery. Follow this procedure to change the back-up battery.

1. Switch the front toggle switch to the STANDBY position.
2. Remove the old battery and insert the new battery.
3. Switch the front toggle switch back to the ON position.

A fresh 9V lithium battery will provide approximately 10 to 15 hours of power to the FA-800E if it is calling out every 15 minutes to all three phone numbers. If it is calling to fewer numbers, calling out every 2 hours or the alarm call-out was cancelled during one of the first calls, the battery life should be longer. Too many variables exist to provide accurate battery life for every condition.

3.7 Disconnecting the FA-800E for Seasonal Storage:

Your FA-800E can provide year round protection, but if desired, it can be safely stored for seasonal use. To store it, disconnect all cables and wires and take out the battery. If you leave a battery in it, the battery will be dead the next time you are ready to use it. Storing electrical devices with batteries in place is not recommended. Store your FA-800E in a dry place with no excessive temperatures.

The FA-800E will indefinitely retain all programmed call-to phone numbers and other programmed settings, even if the power cord is disconnected and the battery has been removed.

4.0 OTHER INSTALLATION NOTES:

4.1 Answering Machines at the Call-To Locations:

If you have an answering machine or voice mail at any of the call-to locations, the FA-800E will generally leave a portion of its alarm message on the answering machine or voice mail. You may want to test this as some answering systems do not pick up the message. Answering machines and voice mail will not affect or stop the call-out sequence in any way.

4.2 Extending the Temperature Sensor Length:

The temperature sensor may be extended using standard, four conductor telephone extension wire up to 100 feet (30.5m) from the FA-800E unit. Extending the sensor more than 100 feet will increase the temperature that the FA-800E senses by about 1°F/C for every 100 feet added. In other words, an extension of 600 feet would give you a temperature that is approximately 5°F/C higher than the actual temperature.

The connection at the end of the temperature sensor that normally plugs into the FA-800E is a male RJ9 connection. This is a smaller connection than a regular telephone line. You can either make or purchase an RJ9 extension wire, or purchase one of our extended sensors separately. They are available in 25', 50' and 90' lengths. Note

that if you are extending sensors outdoors and/or underground, consideration should be given to using shielded wire inside metal conduit. Both shield and conduit should be connected to a ground. This helps prevent stray voltage from interfering with the sensor's signal.

4.3 Extending the Phone Cord Length:

You may use a longer telephone extension cable to place the FA-800E unit at a further distance from an available telephone jack. The FA-800E has been tested to operate on a phone line indoors at a distance of 1,000 feet (304m). Make sure you use four conductor telephone wire. This is available at most hardware and discount department stores. If you are extending this to the outdoors, consideration should be given to using shielded wire inside metal conduit. Both shield and conduit should be connected to a ground.

4.4 Back-Up Battery Options:

The FA-800E has a connection for a 9V battery which can supply power to the unit should the AC power be disconnected or out. A fully charged 9V lithium battery will provide 10 to 15 hours of operation. During this time, however, you will likely receive a "Battery Alarm" call from it meaning the battery has gone below 7.0 volts. Once the battery drops to about 6.0 volts, the FA-800E can no longer operate.

If you wish to have a longer battery option, consider connecting 6 "D" cell alkaline batteries together in series. This produces the required 9V of DC power and also provides about 7 to 10 days of power from fully charged batteries. Emerson Control Products offers a carousel that easily holds six "D" cell batteries and has a wire connected to it for quick connection to the FA-800E's battery terminals.

In addition, the FA-800E can accept up to 12 volts of DC power through the battery connection. Because of this, you could connect a 12 VDC battery to the battery terminals on the FA-800E and have a much longer battery life than even the "D" cell battery option described above. Emerson Control Products has not tested this option nor have we determined the operational life when the FA-800E is running off this battery option.

5.0 COMMONLY ASKED QUESTIONS:

1. I have pulse dialing on my phone line. Can I use the FA-800E?
Yes. There is a pulse/tone dip switch on the back of your FA-800E. Put this switch in the UP position to dial out in pulse dialing mode. If you are programming it locally using a phone plugged into the front, your telephone must be set to tone because the FA-800E's menu structure requires touch tones to operate. Once you have completed the programming functions, you can reset your phone back to pulse mode.
2. I have to dial 9 before I can make a phone call. Can I do this?
Generally, the FA-800E should be able to dial 9 or any other sequence of numbers during a phone call. If you need to dial a number to get an outside line or a dial tone, it is recommended you program in a 9 followed

by a pause. This will allow the phone system time to get the dial tone before the FA-800E begins playing the rest of the digits of your call-to phone number.

3. Do I need a dedicated phone line for my FA-800E?

No. The FA-800E uses any existing single line telephone line. This is discussed in detail on page 6 in section 1.3.

4. If I unplug the FA-800E or take out the battery, will I have to re-program all my telephone numbers and settings?

No. The FA-800E uses a special memory that retains all of your programmed call-to phone numbers and settings indefinitely.

5. How do I reset my FA-800E?

The FA-800E automatically resets itself when the alarm call-out has been canceled and the alarm conditions have been corrected.

6. My temperature sensor is damaged.

We offer replacement temperature sensors. The part number is TS-10-FA. Order from our customer service department.

7. How do I delete one or more phone numbers?

See page 10 for instructions on deleting one or more call-out phone numbers.

6.0 TROUBLESHOOTING:

I did a test and my FA-800E is not calling out to the programmed phone numbers.

Double check that all phone numbers are entered correctly. Did you include a "1" or area codes if necessary? Check the phone line connection. Is the phone cord plugged into the FA-800E and wall jack correctly? Do you have a single line telephone line? If doing a test, did you get it to go into alarm? Is the red alarm light on? If not, re-do the test based on the procedure outlined in the manual.

The FA-800E is not responding when I press the keys on my touch-tone phone.

Check to make sure your phone is set to the tone mode so key presses are in touch-tone mode. Try pressing the keys for different lengths of time – either longer presses or very short presses. Press slowly with ½ second breaks between key presses. If this still does not work, try another phone or dial in remotely to program.

I cannot cancel the alarm call-out because my FA-800E does not answer.

Either the phone lines are down or the power is out and the battery has died preventing the FA-800E from answering the phone. It is also possible the unit has locked up due to a power surge or spike. Do a hard reset as described below.

I am receiving false alarms.

The FA-800E's temperature sensor is accurate to within 3°F of the actual temperature. Your sensor may be too close to a cold window or other colder spot at the monitored location. You may also have the temperature on your thermostat set too close to the temperature alarm setpoint on your FA-800E. Either change the thermostat setting or your temperature alarm setpoint so there is a 5 degree difference in temperature.

All the lights are off on my FA-800E

If the power is out or the power cord is unplugged, the lights on the FA-800E will not be illuminated. This is designed to save battery power during a power failure. This could also signal that something serious has happened to your FA-800E. Check power connections and if you still have no lights, call Customer Service.

I am getting a temperature reading of 302°F (150°C).

If you are receiving a very high temperature sensor reading, your temperature sensor is either unplugged, not plugged in correctly or it has been damaged. Replacement sensors are available. Sensor part number is TS-10-FA.

The alarm light is blinking

This means your FA-800E is in STANDBY mode.

I have canceled the alarm call-out, but the unit immediately calls me back and continues to call the three phone numbers even after repeated “cancellations”.

There may be fluctuating temperature or power status that is causing the unit to reset almost immediately and then call back. Another possibility is the unit is locked up and for some reason, it resets and calls out even when the alarm call-out has been previously cancelled. If this occurs, go into the programming menu and delete the three phone numbers until you can get to the property and try a reset of the unit. See page 11 for details on deleting a phone number.

Is there any way to reset the unit to get it back to normal? Or, how do I perform a “hard reset”?

*To get the unit back to factory settings, you would have to change all the programmed settings back to factory defaults. There is, however, a **HARD RESET** option that does not change any of the programmed settings or phone numbers, but should bring the unit back to normal operating function. Remove the power cord, battery, temp sensor and phone line. Let the unit sit for 1 or 2 minutes and then plug back in the connections in the following order: Temp sensor, power cord, battery and then the telephone cord.*

7.0 WARRANTY AND REPAIR INFORMATION:

7.1 Contacting Us:

For more information about your FA-800E, contact one of our Customer Service Representatives at:

Phone: 800-880-8000

Email: cpi-customerservice@emerson.com

Or visit us at: www.controlproductsonline.com

Replacement temperature sensors are available. Order the TS-10-FA from Customer Service.

7.2 Limited Warranty:

Warrantor: Dealer, Distributor, Retailer, Manufacturer

Warranty and Remedy:

We believe the FA-800E is a superior product. Although we take extreme pride in producing and testing a product that will function properly, we cannot guarantee that there will never be a defective unit or that a unit will function on all the thousands of phone lines and communication equipment in existence. For this reason, it must be clear that the Warrantors are not insuring your premises or guaranteeing that there will not be damage to your person or property if you use this Product. If you are not comfortable with our Limited Warranty, or completely satisfied with the Product, we encourage you to return the unused Product for a full refund within 30 days of purchase. Thank you for your understanding.

One Year Limited Warranty - Emerson Control Products, Inc. warrants its product to be free from defects in material and workmanship under normal use for one year, and is not responsible for consequential damages or installation costs of any nature. In the event that the Product does not conform to this Warranty at any time during the period of one year from original purchase date, Warrantor will repair the defect and return it to you at no charge. **IMPORTANT:** The Warranty is limited to replacement of the Product ONLY. Secondly, because every phone line differs, we strongly encourage you to fully test this Product in its actual application. This should include a full test, involving the Product actually dialing to its designated locations and someone verifying the proper response.

This Warranty shall terminate and be of no further effect at the time the Products is 1) damaged by extraneous causes such as fire, water, power surge, electrical spike, lightning, etc., or not maintained as reasonable and necessary; 2) modified; 3) improperly installed; 4) repaired by someone other than the Warrantor; 5) used in a manner or purpose for which the Product was not intended.

WARRANTORS' OBLIGATION UNDER THIS WARRANTY IS LIMITED TO REPAIR OR REPLACEMENT OF THE PRODUCT ONLY. THIS WARRANTY DOES NOT COVER PAYMENT OR PROVIDE FOR THE REIMBURSEMENT OF PAYMENT FOR INCIDENTAL OR CONSEQUENTIAL DAMAGES.

It must be clear that the Warrantors are not insuring your premises or guaranteeing that there will not be damage to your person or property if you use this Product. The Warrantors shall not be liable under any circumstances for damage to your person or property or some other person or that person's property by reason of the sale or use of this Product, or its failure to operate in the manner in which it is designed. The Warrantors' liability, if any, shall be limited to the original cost of the Product only. Use of this product is at your own risk.

7.3 Repair and Service:

In the event that the Product does not conform to this Warranty, the Product should be shipped or delivered freight prepaid to Warrantor with evidence of original purchase. If in any way you're not comfortable with this product or its Limited Warranty, we encourage you to return it, unused within 30 days of original purchase date with evidence of the purchase date.

The FA-800E should only be repaired by Emerson Control Products or an authorized service representative. Do not attempt to repair or fix your FA-800E or have it serviced by anyone other than an authorized service representative or you will void your warranty.

To return a product to Emerson Control Products:

All products being returned to Emerson Control Products must have a valid Returned Goods Authorization Number (RGA #) from Emerson Control Products, regardless of why the product is being returned. Warranty returns will be honored only with an RGA #. Ship warranty return products prepaid to Emerson Control Products, 1724 Lake Drive West, Chanhassen, MN 55317. Emerson Control Products will, at its option, either repair or replace the product free of charge and return the repaired unit or replacement unit at the lower cost shipping prepaid. Products returned for credit are subject to a 25% restocking charge. Returns resulting from errors by the seller are not subject to this charge. All returns must include evidence of original purchase, showing purchase date. The RGA # should be clearly marked on the outside of the package containing the product.

To request an RGA #, call Emerson Control Products at 800-880-6000 and ask for Customer Service. Failure to have an RGA # may result in lost product or significant delays in handling your return. Products without an RGA # clearly marked on the outside of the package are not the responsibility Emerson Control Products.

8.0 FCC & UL CERTIFICATION STATEMENTS:

FCC – PART 68: This equipment complies with Part 68 of the FCC rules and the requirements adopted by the ACTA. On the back of your FA-800E is a label that contains, among other information, a product identifier in the format US:AAAEQ##TXXXX. If requested, this number must be provided to the telephone company.

A plug and jack used to connect this equipment to the premises wiring and telephone network must comply with the applicable FCC Part 68 rules and requirements adopted by the ACTA. A compliant telephone cord and modular plug is provided with this product. It is designed to be connected to a compatible modular jack that is also compliant. See installation instructions for details.

The REN is used to determine the number of devices that may be connected to a telephone line. Excessive REN's on a telephone line may result in the devices not ringing in response to an incoming call. In most but not all areas, the sum of REN's should not exceed five (5.0). To be certain of the number of devices that may be connected to a line, as determined by the total REN's, contact your local telephone company. The REN for this product is shown above and is also identified as part of the FCC product identifier shown on the label on the back of your FA-800E. The REN for other devices will be identified on a label on the product in the FCC product identifier or listed separately. If there is a product identifier number, it will be in a format as US:AAAEQ##TXXXX. The ## is the REN number shown without a decimal point (e.g., 03 is a REN of 0.3).

If this FA-800E causes harm to the telephone network, the telephone company will notify you in advance that temporary discontinuance of service may be required. But if advance notice isn't practical, the telephone company will notify the customer as soon as possible. Also, you will be advised of your right to file a complaint with the FCC if you believe it is necessary.

The telephone company may make changes in its facilities, equipment, operations or procedures that could affect the operation of the equipment. If this happens, the telephone company will provide advance notice in order for you to make necessary modifications to maintain uninterrupted service.

If trouble is experienced with your FA-800E, for repair or warranty information, please contact Emerson Control Products at 800-852-8244. Other contact numbers and information can be found at the end of this instruction manual. If the equipment is causing harm to the telephone network, the telephone company may request that you disconnect the equipment until the problem is resolved. The FA-800E should be repaired only by Emerson Control Products or an authorized service representative. Contact Emerson Control Products for the nearest authorized service representative.

Connection to party line service is subject to state tariffs. Contact the state public utility commission, public service commission or corporation commission for information.

If your home has specially wired alarm equipment connected to the telephone line ensure the installation of your FA-800E does not disable your alarm equipment. If you have questions about what will disable alarm equipment, consult your telephone company or a qualified installer.

FCC – PART 15: This equipment has been tested and found to comply with the limits for a Class B digital device, pursuant to Part 15 of the FCC rules. These limits are designed to provide reasonable protection against harmful interference in a residential installation. This equipment generates, uses and can radiate radio frequency energy and, if not installed and used in accordance with the instructions, may cause harmful interference to radio communications. However, there is no guarantee that interference will not occur in a particular installation. If this equipment does cause harmful interference to radio or television reception, which can be determined by turning the equipment off and on, the user is encouraged to try to correct the interference by one or more of the following measures:

- Reorient or relocate the receiving antenna
- Increase the separation between the equipment and the receiver
- Connect the equipment into an outlet on a circuit different from that which the receiver is connected.
- Consult the dealer or an experienced radio/television technician for help.

Canada's Industry Standard:

Notice: The Canadian Industry Standard label identifies certified equipment. This certification means the equipment meets certain telecommunications network protective operational and safety requirements. The Department does not guarantee the equipment will operate to the user's satisfaction.

Before installing this equipment, users should ensure that it is permissible to be connected to the facilities of the local telecommunications company. The equipment must also be installed using an acceptable method of connection. In some cases, where the company's inside wiring

is associated with a single line, individual service may be extended by means of a certified connector assembly (telephone extension cord). The customer should be aware that compliance with the above conditions may not prevent degradation of service in some situations.

Repairs to certified equipment should be made by an authorized Canadian maintenance facility designated by the supplier. Any repairs or alterations made by the user to this equipment, or equipment malfunctions, may give the telecommunications company cause to request the user to disconnect the equipment.

Users should ensure for their own protection that the electrical ground connections of the power utility telephone lines and internal metallic water pipe system, if present, are connected together. This precaution may be particularly important in rural areas.

CAUTION: Users should not attempt to make such connections themselves, but should contact the appropriate electric inspection authority, or electrician, as appropriate.

UL & CUL Listing:

The plug in transformer included with your FA-800E is UL/CUL listed as a Class 2 Transformer. This is UL/CUL listed with Besler Electric under file number E84666.

APPENDIX A Main and Program Menu Flow Chart

Main Menu

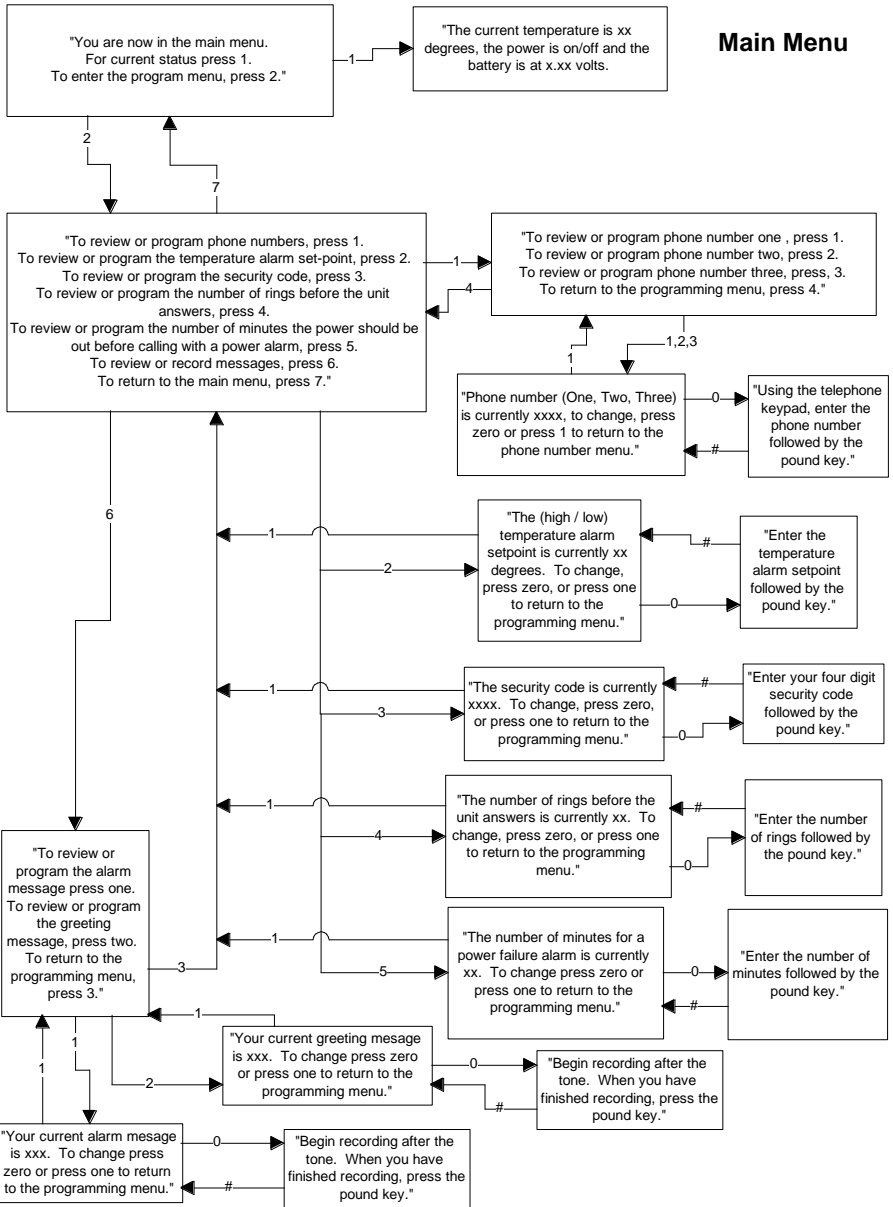

Call-In Menu

What you will hear when you call into your FA-800E from a remote location

Call in menu

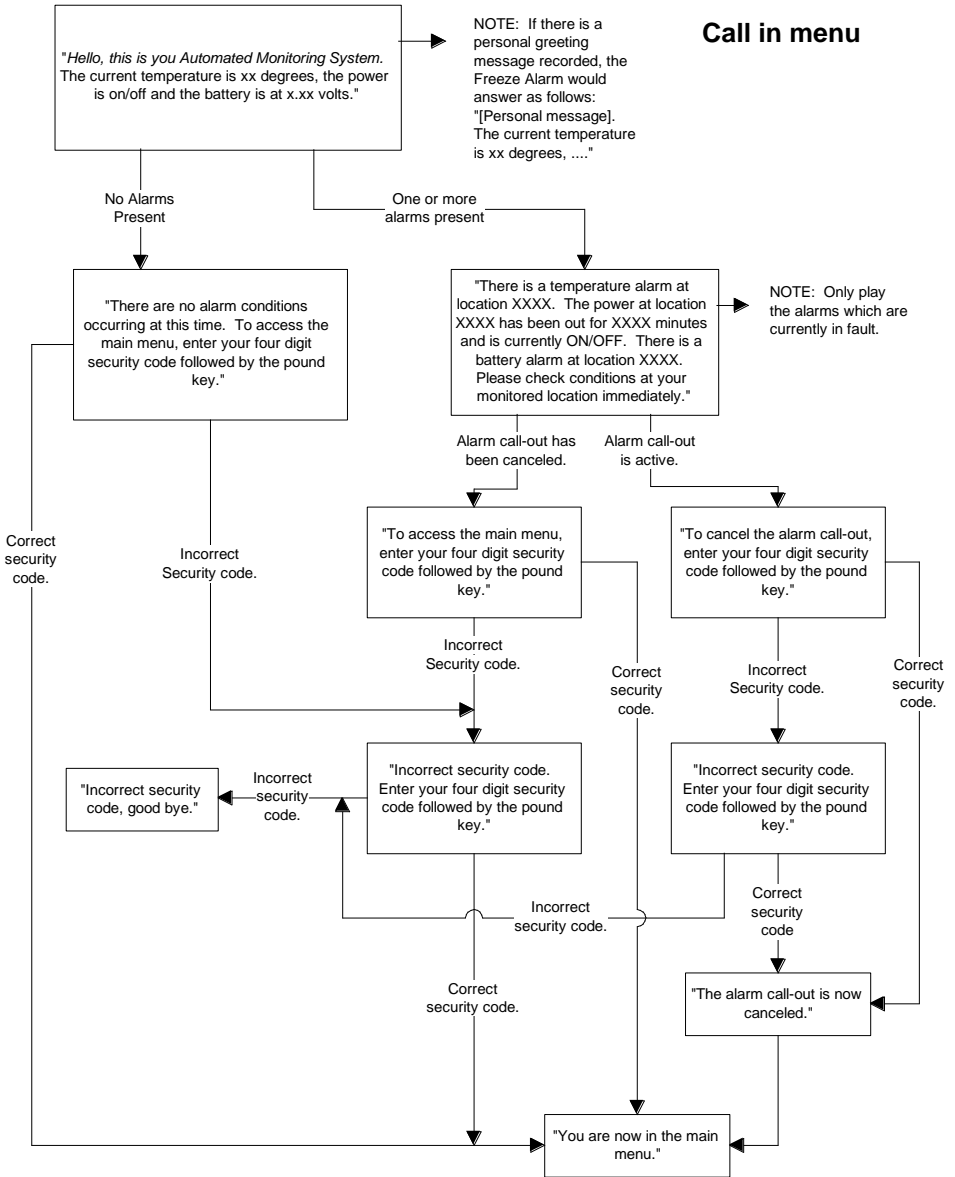

Call-Out Menu

What you will hear when the FA-800E calls you with an alarm

Call out menu

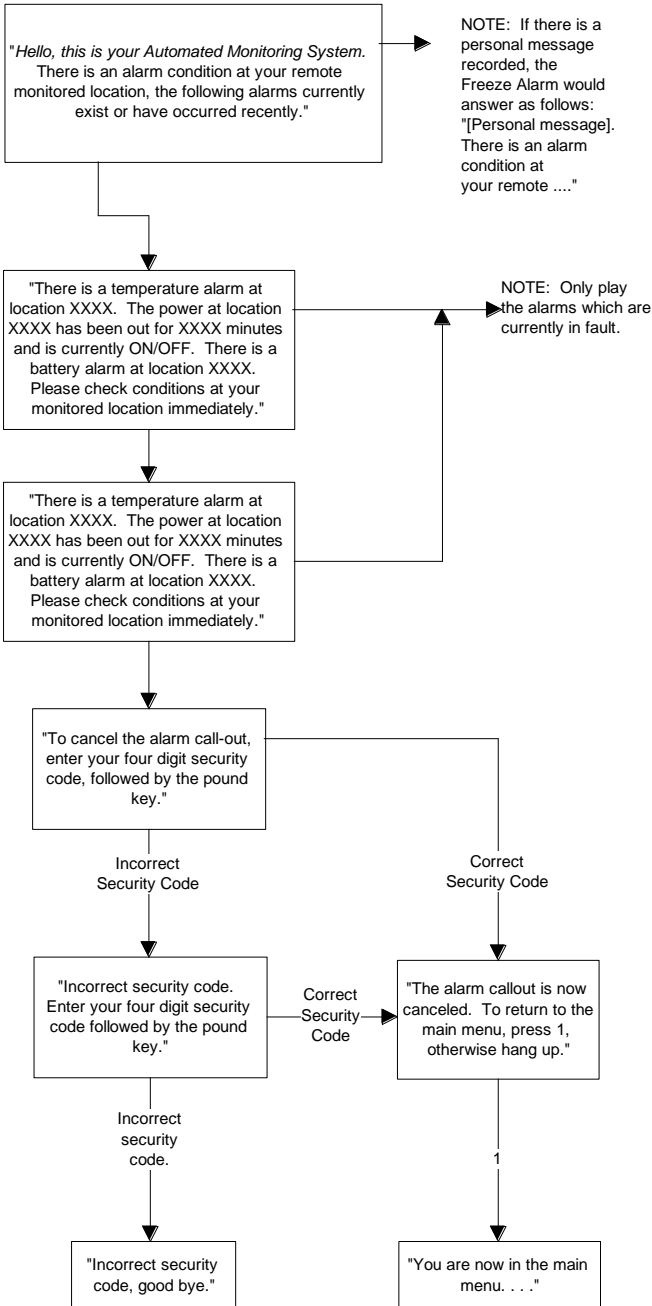



Emerson Control Products Inc.
Chanhassen, Minnesota USA

Document 42420125A